

Z_2 invariant for topological magnon insulators

Hosho Katsura (桂 法称)

Department of Physics, UTokyo

Collaborators:

Yutaka Akagi (UTokyo)

Hiroki Kondo (UTokyo)

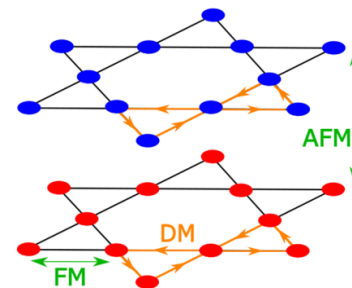

- H. Kondo, Y. Akagi & HK, arXiv:1808.09149

Outline

1. Introduction & motivation

- What are topological insulators (TI)?
- Disordered TI
- What about boson?

2. Magnon Hall effect

3. Magnetic analog of 2D class All Topo. Ins.

4. Summary

What are topological insulators (TI)?

- Band insulators (free-fermions)
- Characterized by **topological invariants**
TKNN invariant = Chern #
- Robust gapless **edge/surface states**

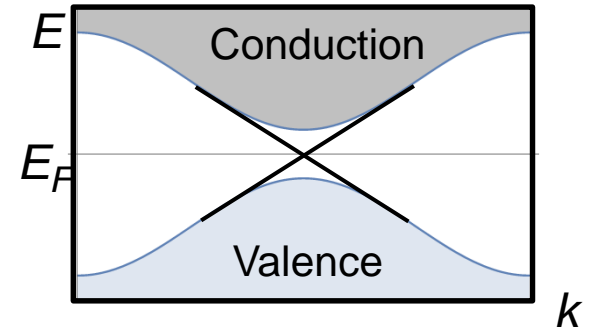

Reviews and textbooks:

M.Z. Hasan and C.L. Kane, *RMP.* **82**, 3045 (2010).

X-L. Qi and S-C. Zhang, *RMP.* **83**, 1057 (2010), ...

■ Examples

- Integer quantum Hall effect ('80s) Magnetic field
von Klitzing *et al.*, TKNN
- **2D** Quantum spin Hall effect Spin-orbit
Kane-Mele ('05), Molenkamp's group, ...
- **3D** TI ($\text{Bi}_{1-x}\text{Sb}_x$, Bi_2Se_3 , Bi_2Te_3)
Fu-Kane-Mele, Hasan's group, ...

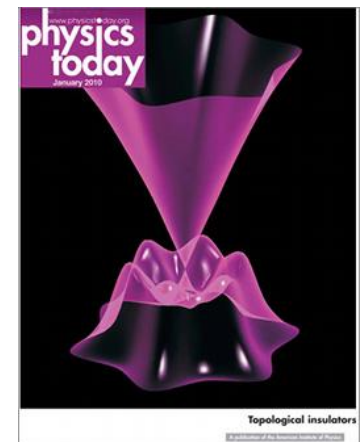

Periodic Table -- Classification of TI & SC --

Symmetries: **Time-reversal(T)**, **particle-hole(C)** & **Chiral(S)**.

Topo. Numbers: $\mathbf{Z}_2 = \{0,1\}$, $\mathbf{Z} = \{0, \pm 1, \pm 2, \dots\}$, $2\mathbf{Z} = \{0, \pm 2, \pm 4, \dots\}$

Schnyder *et al.*, *PRB* **78** (2008); Kitaev, AIP Conf. Proc. **1134** (2008).

Symmetry				Spatial dimension d							
CAZ	TRS	PHS	CHS	1	2	3	4	5	6	7	8
A	0	0	0		\mathbf{Z}		\mathbf{Z}		\mathbf{Z}		\mathbf{Z}
AIII	0	0	1	\mathbf{Z}		IQHE		\mathbf{Z}		\mathbf{Z}	
AI	+1	0	0				$2\mathbf{Z}$		\mathbf{Z}_2	\mathbf{Z}_2	\mathbf{Z}
BDI	+1	+1	1	\mathbf{Z}		p+ip SC		$2\mathbf{Z}$		\mathbf{Z}_2	\mathbf{Z}_2
D	0	+1	0	\mathbf{Z}_2	\mathbf{Z}				$2\mathbf{Z}$		\mathbf{Z}_2
DIII	-1	+1	1	\mathbf{Z}_2	\mathbf{Z}_2	\mathbf{Z}				$2\mathbf{Z}$	
AII	-1	0	0		\mathbf{Z}_2	\mathbf{Z}_2	\mathbf{Z}				$2\mathbf{Z}$
CII	-1	-1	1	QSHE		\mathbf{Z}	3D TI		\mathbf{Z}		
C	0	-1	0		$2\mathbf{Z}$		\mathbf{Z}_2	\mathbf{Z}_2	\mathbf{Z}		
CI	+1	-1	1			$2\mathbf{Z}$		\mathbf{Z}_2	\mathbf{Z}_2	\mathbf{Z}	

Bott
Periodicity

Can be refined with additional symmetry, e.g., inversion.

What about bosons?

■ Eigenvalue problem

- Fermionic quadratic form can be diagonalized by **unitary** tr.
- Bosonic quadratic form can be diagonalized by **para-unitary** tr.

■ Fermion v.s. boson in 2D

Fermion (electron)	Boson (magnon)
<p>Chern insulator (A)</p> <p>Hall effect (quantized)</p> <p>Chern (TKNN) number</p>	<p>Topo. magnon insulator</p> <p>Thermal Hall effect (not quantized)</p> <p>Chern (TKNN) number</p>
<p>Quantum spin Hall ins. (All)</p> <p>Spin Hall effect</p> <p>Z₂ (Kane-Mele) invariant</p>	<p><i>What's the counterpart?</i></p> <p><i>What's topo. invariant?</i></p> <p><i>(What's TR symmetry?)</i></p>

Outline

1. Introduction & motivation

2. **Magnon Hall effect**

- Chern insulators
- Thermal Hall effect
- Magnon Chern insulators
- Examples

3. Magnetic analog of 2D class All Topo. Ins.

4. Summary

Chern insulators

■ TKNN formula Thouless *et al.*, *PRL*, **49** (1982)

- Bloch wave function $\psi_n(\mathbf{k})$
- Berry connection $\mathbf{A}_n(\mathbf{k}) = i \langle \psi_n(\mathbf{k}), \nabla_{\mathbf{k}} \psi_n(\mathbf{k}) \rangle$
- Berry curvature $\Omega_n(\mathbf{k}) = [\nabla_{\mathbf{k}} \times \mathbf{A}_n(\mathbf{k})]_z$

Chern number

$$N = - \sum_{n \in \text{occ.}} \int_{\text{BZ}} \frac{d^2 k}{(2\pi)^2} \Omega_n(\mathbf{k})$$



$$\sigma_{xy} = N \frac{e^2}{h}$$

■ Examples

- Haldane's model (*PRL* **61**, 2015 (1988), Nobel prize 2016)

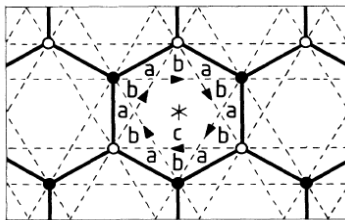

Zero net magnetic field.

But local field breaks TRS!

n.n. real and n.n.n. complex hopping \rightarrow Integer QHE

- Ohgushi-Murakami-Nagaosa (*PRB* **62** (2000))

A similar model on kagome derived from double-exchange model

Thermal Hall effect

■ Righi-Leduc effect

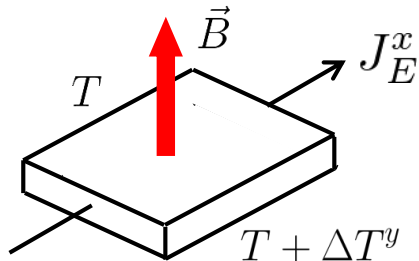

Transverse temperature gradient is produced in response to heat current

In itinerant electron systems
from Wiedemann-Franz

$$\kappa_{xy} = LT\sigma_{xy}$$

■ TKNN-like formula for bosons

- Bloch w.f. $\psi_n(\mathbf{k})$, Berry curvature $\Omega_n(\mathbf{k})$

- Earlier work had some flaw...

H.K., Nagaosa & Lee, *PRL* **104**; Onose *et al.*, *Science* **329**, (2010)

- Modified linear-response theory

Matsumoto & Murakami, *PRL* **106**, 197202; *PRB* **84**, 184406 (2011)

$$\kappa_{xy} = -\frac{k_B^2 T}{\hbar} \sum_n \int_{\text{BZ}} \frac{d^2 k}{(2\pi)^2} c_2(\rho_n(\mathbf{k})) \Omega_n(\mathbf{k})$$

$$c_2(\rho) = (1 + \rho) \left(\ln \frac{1 + \rho}{\rho} \right) - (\ln \rho)^2 - 2\text{Li}_2(-\rho)$$

NOTE) No quantization.

What are magnons?

■ Intuitive picture

FM GS

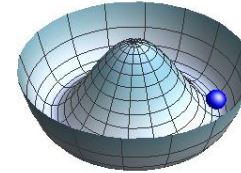
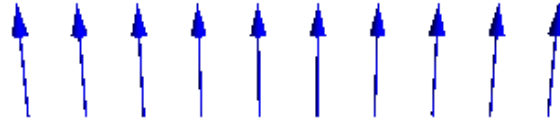

Excitation
=NG mode

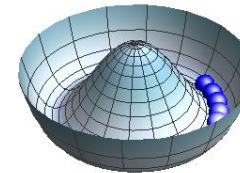
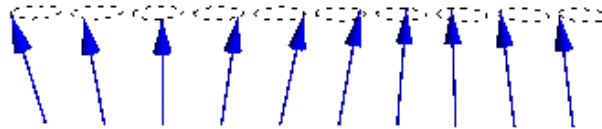

$$E(k) \propto k^2$$

■ Holstein-Primakoff transformation

- Bose operators

$$[b_i, b_j^\dagger] = \delta_{ij}, \quad [b_i, b_j] = [b_i^\dagger, b_j^\dagger] = 0$$

$$\text{Number op.: } n_i = b_i^\dagger b_i$$

- Spins in terms of b

$$S_j^+ = \sqrt{2S - n_j} b_j, \quad S_j^- = b_j^\dagger \sqrt{2S - n_j}, \quad S_j^z = S - n_j$$

Obey the commutation relations of spins

Often neglect nonlinear terms. $S_j^+ \sim \sqrt{2S} b_j, \quad S_j^- \sim \sqrt{2S} b_j^\dagger$

- Magnetic ground state = vacuum of bosons $b_j |\text{vac}\rangle = 0$

Magnon Chern insulators

■ Kagome model

$$H = \sum_{\langle i,j \rangle} [-J \mathbf{S}_i \cdot \mathbf{S}_j + \underline{D_{ij} \cdot (\mathbf{S}_i \times \mathbf{S}_j)}]$$

$$-\tilde{J} S(e^{i\phi} b_i^\dagger b_j + e^{-i\phi} b_j^\dagger b_i) + \dots$$

$$\tilde{J} = \sqrt{J^2 + D^2}, \quad \tan \phi = D/J$$

DM vectors

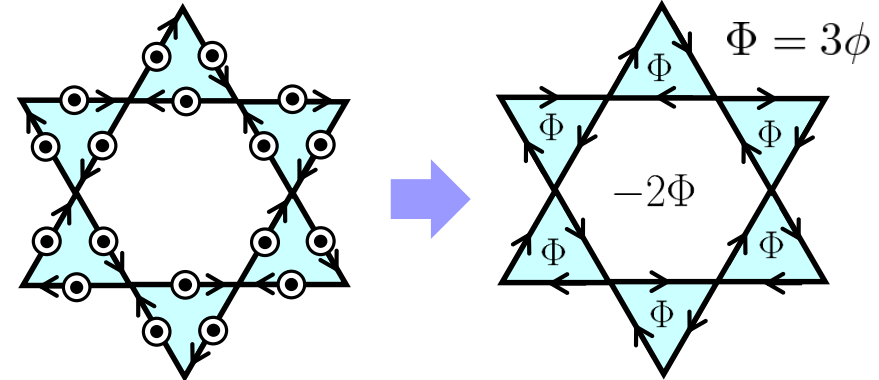

Bosonic ver. of Ohgushi's model!

Scalar chirality order there $\mathbf{S}_i \cdot (\mathbf{S}_j \times \mathbf{S}_k) \leftrightarrow \text{DM}$.

Nonzero Berry curvature! κ_{xy} is expected to be nonzero.

■ MOF material Cu(1-3, bdc)

FM exchange int. b/w Cu^{2+} moments

- Hirschberger *et al.*, *PRL* **115**, 106603 (2015)
- Chisnell *et al.*, *PRL* **115**, 147201 (2015)

Nonzero THE response.

Sign change consistent with theories:

Mook, Henk & Mertig *PRB* **89**, 134409 (2014),

Lee, Han & Lee, *PRB* **91**, 125413 (2015).

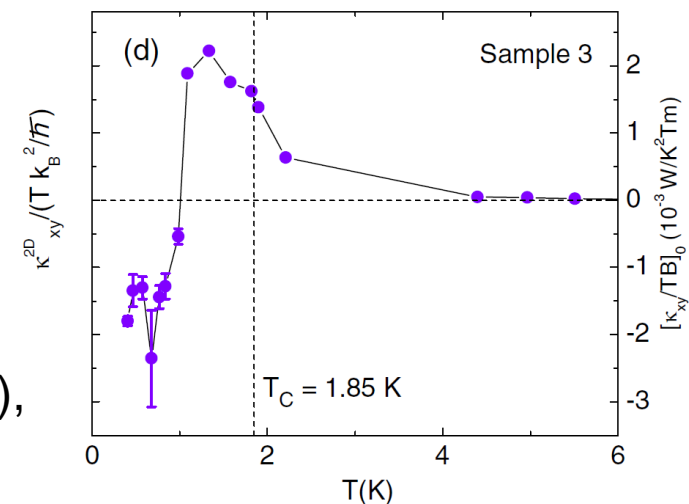

Magnon Hall effect in 3D

■ Pyrochlore ferromagnet $\text{Lu}_2\text{V}_2\text{O}_7$

Onose *et al.*, *Science* **329**, 297 (2010)

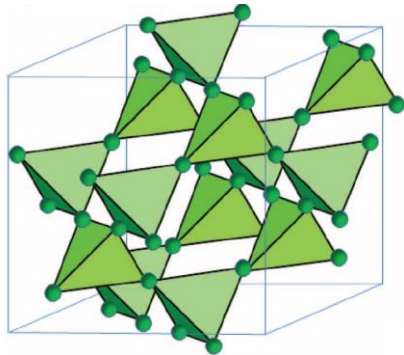

- V^{4+} : $(t_{2g})^1$, $S=1/2$
- Insulator
- Isotropic ferromagnet ($T_c=70\text{K}$)
- $\kappa_{xy} \neq 0$ below T_c
- “Spontaneous” component

Theoretical model (Heisenberg + DM) well explains the magnon Hall effect!

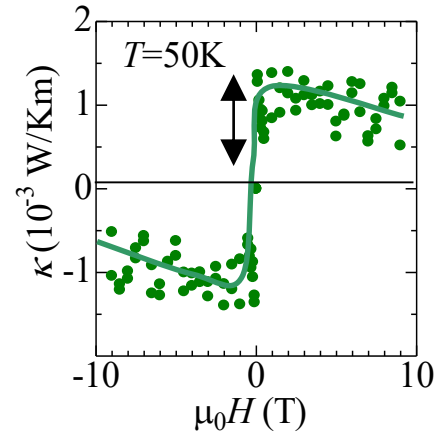

Estimate of FM int.
 $|D/J| \sim 0.38$

■ Other materials

Ideue *et al.*, *PRB* **85**, 134411 (2012)

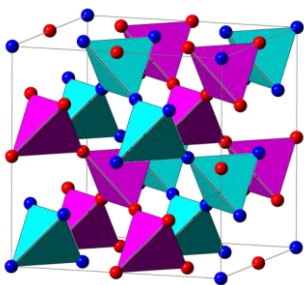

$\text{Ho}_2\text{V}_2\text{O}_7$
 $\text{In}_2\text{Mn}_2\text{O}_7$

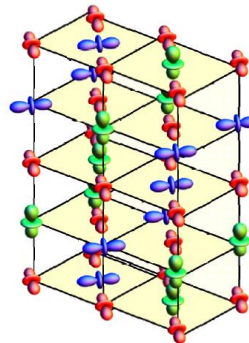

BiMnO_3

$\kappa_{xy} = 0$ in YTiO_3 and $\text{La}_2\text{NiMnO}_6$
consistent with the DM scenario
(Zero Berry curvature)

Topological boson systems

■ Thermal Hall effects of bosonic particles

- Phonon:

(Exp.) Strohm, Rikken, Wyder, *PRL* **95**, 155901 (2005)

(Theory) Sheng, Sheng, Ting, *PRL* **96**, 155901 (2006)

Kagan, Maksimov, *PRL* **100**, 145902 (2008)

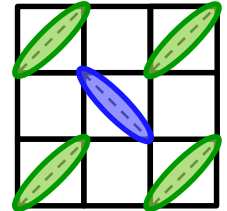

- Triplon: (Theory) Romhanyi, Penc, Ganesh, *Nat. Comm.* **6**, 6805 (2015)

- Photon: (Theory) Ben-Abdallah, *PRL* **116**, 084301 (2016)

■ Topological magnon physics

- Dirac magnon

Honeycomb: Fransson, Black-Schaffer, Balatsky, *PRB* **94**, 075401 (2016)

- Weyl magnon

Pyrochlore AFM: F-Y. Li *et al.*, *Nat. Comm.* **7**, 12691 (2016)

Pyrochlore FM: Mook, Henk, Mertig, *PRL* **117**, 157204 (2016)

- Topological insulators

Nakata, Kim, Klinovaja, Loss, *PRB* **96**, 224414 (2017)

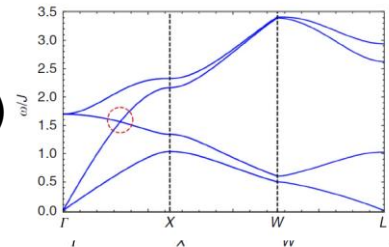

Outline

1. Introduction & motivation

2. Magnon Hall effect

3. Magnetic analog of 2D class All Topo. Ins.

- Kramers pairs and Z_2 invariant (electrons)
- Magnon spin Nernst effect
- Kramers pairs and Z_2 invariant (magnons)
- Examples, helical edge states

4. Summary

Kramers pairs

■ Time-reversal symmetry (TRS)

- Quadratic form $H(\mathbf{k})$ (in k -space)

$$\mathcal{H} = \sum_{\mathbf{k}} (\mathbf{c}_{\uparrow}^{\dagger}, \mathbf{c}_{\downarrow}^{\dagger}) \begin{pmatrix} h_{\uparrow\uparrow}(\mathbf{k}) & h_{\uparrow\downarrow}(\mathbf{k}) \\ h_{\uparrow\downarrow}(\mathbf{k}) & h_{\downarrow\downarrow}(\mathbf{k}) \end{pmatrix} \begin{pmatrix} \mathbf{c}_{\uparrow} \\ \mathbf{c}_{\downarrow} \end{pmatrix} \quad \text{Annihilation op.}$$

$$\mathbf{c}_{\sigma} = [c_{1\sigma}(\mathbf{k}), \dots, c_{N\sigma}(\mathbf{k})]^T$$

- (Odd) Time reversal

$$\Theta = UK$$

$$H(-\mathbf{k}) = \Theta H(\mathbf{k}) \Theta^{-1}$$

Antiunitary!

Standard choice: $\Theta = (i\sigma_y \otimes 1_N)K$ with $\Theta^2 = -1$.

- Important property $\langle \Theta\psi, \Theta\varphi \rangle = \langle \varphi, \psi \rangle$

■ Kramers degeneracy

Suppose $\psi(\mathbf{k})$ is an eigenstate of $H(\mathbf{k})$ with energy $E(\mathbf{k})$.

Then, $\varphi(-\mathbf{k}) := \Theta\psi(\mathbf{k})$ is an eigenstate of $H(-\mathbf{k})$ with the same energy.

They form a **Kramers pair**.

At time-reversal invariant momentum (TRIM), $\langle \psi(\mathbf{k}), \varphi(\mathbf{k}) \rangle = 0$

Z2 topological invariant

- Band structure

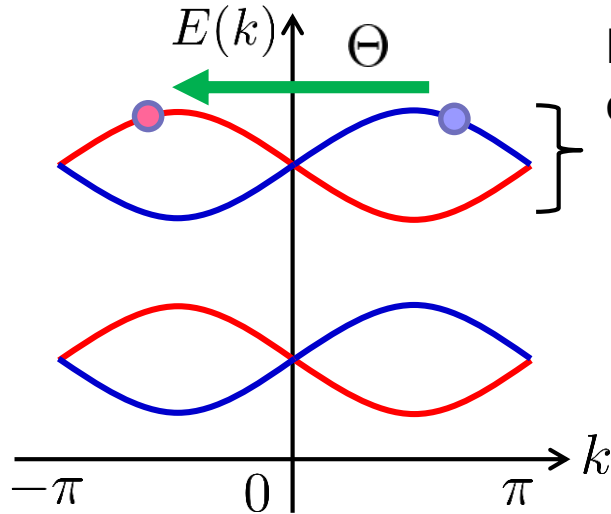

Kramers pair
of bands

$$\psi_{n,\alpha}(\mathbf{k})$$

n : band index

α : label for doublet

- Berry connection

$$\mathbf{A}_{n,\alpha}(\mathbf{k}) = i \langle \psi_{n,\alpha}(\mathbf{k}), \nabla_{\mathbf{k}} \psi_{n,\alpha}(\mathbf{k}) \rangle$$

- Berry curvature

$$\Omega_n(\mathbf{k}) = [\nabla_{\mathbf{k}} \times \mathbf{A}_{n,\alpha}(\mathbf{k})]_z$$

■ Fu-Kane formula of Z2

- Z2 index

Fu & Kane, *PRB* **74**, 195312 (2006).

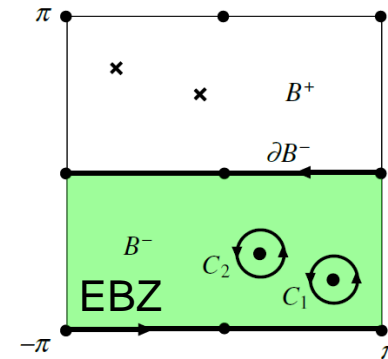

$$D_n = \frac{1}{2\pi} \sum_{\alpha=I,II} \left(\oint_{\partial\text{EBZ}} d\mathbf{k} \cdot \mathbf{A}_{n,\alpha}(\mathbf{k}) - \int_{\text{EBZ}} d^2k \Omega_{n,\alpha}(\mathbf{k}) \right) \text{ mod } 2$$

Kane-Mele model

■ Hamiltonian

Kane & Mele, *PRL* **95**, 146802; 226801 (2005)

$$H = t \sum_{\langle ij \rangle} c_i^\dagger c_j + i\lambda_{SO} \sum_{\langle\langle ij \rangle\rangle} v_{ij} c_i^\dagger s^z c_j + i\lambda_R \sum_{\langle ij \rangle} c_i^\dagger (\mathbf{s} \times \hat{\mathbf{d}}_{ij})_z c_j + \lambda_v \sum_i \xi_i c_i^\dagger c_i.$$

- Two coupled Haldane models
When $\lambda_R=0$, up and down spins are decoupled.
Two edge states propagate in opposite directions.

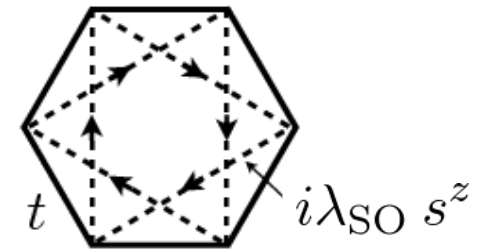
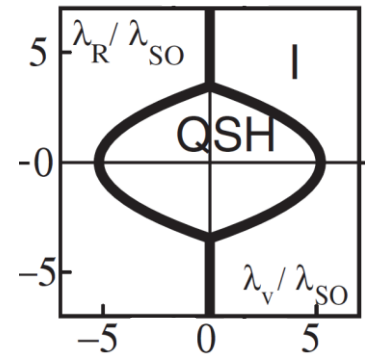

■ Z2 invariant

Each Kramers pair of bands is Z2 nontrivial
→ Helical edge states!

Leading to spin-Hall effect

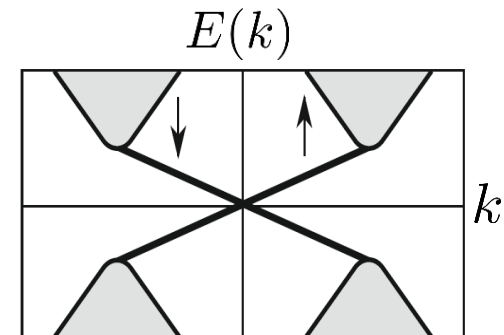
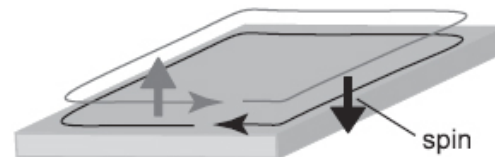

What is magnetic analog?

- Anti-ferromagnetically coupled 2D ferromagnets

Up/down electrons \longleftrightarrow magnons at layer 1/2

■ Magnon spin Nernst effect

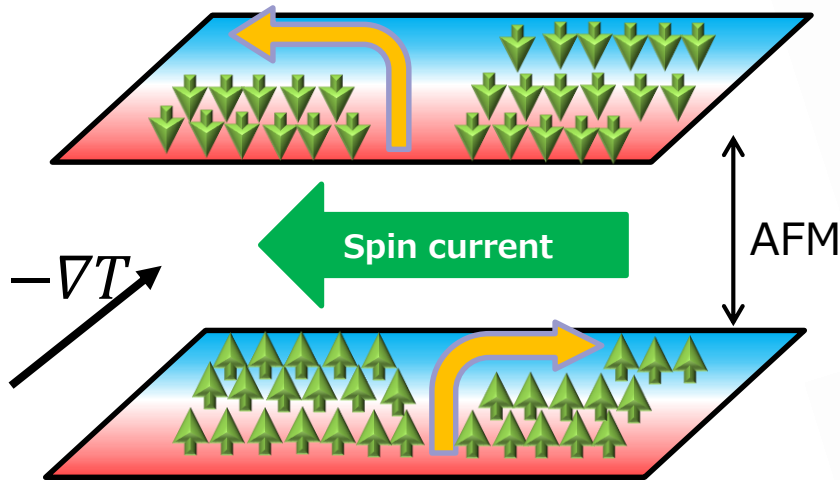

V.A. Zyuzin *et al.*, *PRL* **117** ('16).
K. Nakata *et al.*, *PRB* **96** ('17).

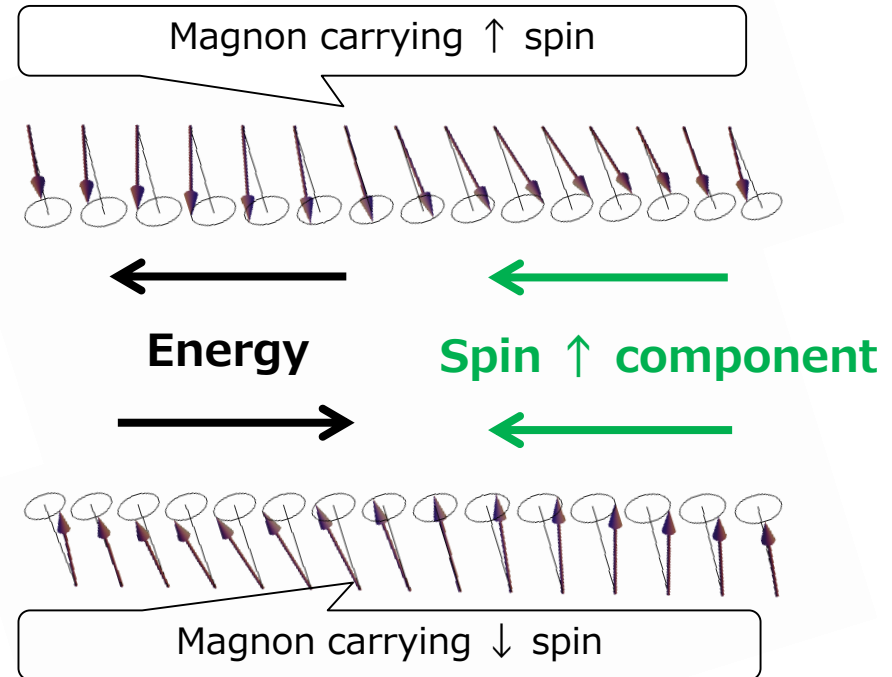

■ Pseudo time-reversal symmetry?

System is invariant under TR PLUS the interchange of the layers.

Bosonic quadratic form

- Hamiltonian

$$\mathcal{H} = \frac{1}{2} \sum_{\mathbf{k}} [\beta^\dagger(\mathbf{k}) \beta(-\mathbf{k})] H(\mathbf{k}) \begin{bmatrix} \beta(\mathbf{k}) \\ \beta^\dagger(-\mathbf{k}) \end{bmatrix} \quad \beta(\mathbf{k}) = [b_\uparrow(\mathbf{k}), b_\downarrow(\mathbf{k})]^\top$$

$b_\sigma(\mathbf{k}) : N\text{-component vec.}$

- **Para-unitary** transformation

See, e.g., Colpa, *Physica* **93A**, 327 (1978).

$$\begin{pmatrix} \gamma(\mathbf{k}) \\ \gamma^\dagger(-\mathbf{k}) \end{pmatrix} = \mathcal{T} \begin{pmatrix} \beta(\mathbf{k}) \\ \beta^\dagger(-\mathbf{k}) \end{pmatrix} \quad \text{Should leave the boson commutations unchanged.}$$

$$\mathcal{T} \Sigma_z \mathcal{T}^\dagger = \mathcal{T}^\dagger \Sigma_z \mathcal{T} = \Sigma_z \quad \Sigma_z = \sigma_z \otimes 1_{2N}$$

- Diagonalization

$$\mathcal{T}^\dagger H(\mathbf{k}) \mathcal{T} = \begin{pmatrix} E(\mathbf{k}) & 0 \\ 0 & -E(\mathbf{k}) \end{pmatrix} \quad E(\mathbf{k}) = \text{diag}[E_1(\mathbf{k}), \dots, E_{2N}(\mathbf{k})]$$

$E_n(\mathbf{k})$ are positive eigenvalues of $\Sigma_z H(\mathbf{k})$. **Non-Hermitian!**

- Modified inner product $\langle\langle \psi, \varphi \rangle\rangle := \langle \psi, \Sigma_z \varphi \rangle$

Bosonic Kramers pair?

■ Pseudo time-reversal symmetry

• Operation $\Theta' = PK \quad (\Theta')^2 = -1 \quad P: \text{para-unitary}$

• Ex) $\Theta' = (\overbrace{\sigma_z}^{\text{p-h}} \otimes \overbrace{i\sigma_y}^{\text{up/down}} \otimes 1) K$

• Symmetry $\Sigma_z H(-\mathbf{k}) = \Theta' \Sigma_z H(\mathbf{k}) (\Theta')^{-1}$

• Property $\langle\langle \Theta' \psi, \Theta' \varphi \rangle\rangle = \langle\langle \varphi, \psi \rangle\rangle$

■ Kramers degeneracy

• Kramers pair $\Psi_{n,1,+}(\mathbf{k}), \Psi_{n,2,+}(-\mathbf{k})$
 (para) orthogonal at TRIM

• Particle-hole pair
 $\Psi_{n,1,+}(\mathbf{k}), \Psi_{n,1,-}(-\mathbf{k})$

Pair of particle bands and its hole conjugate have the same Berry connection.

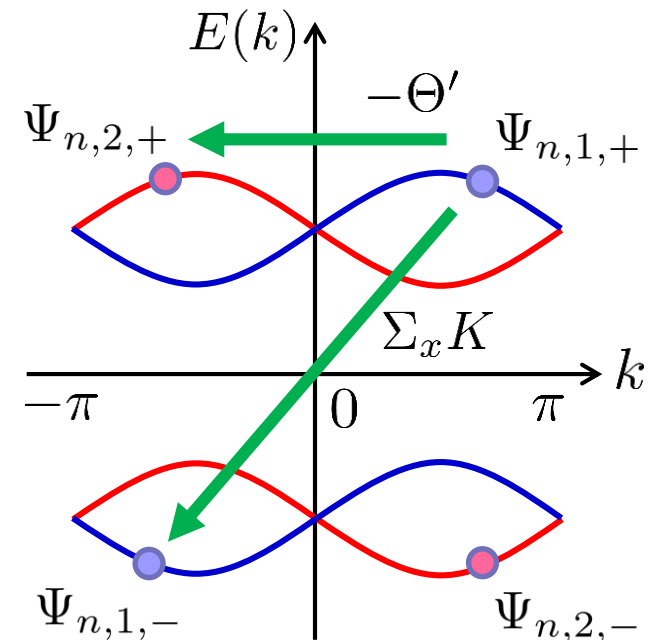

Z2 Topological invariant

■ Fu-Kane like formula

- (Particle) w.f.: $\psi_{n,\alpha}(\mathbf{k}) = \Psi_{n,\alpha,+}(\mathbf{k})$ n : band index
 α : label for doublet
- Berry Connection $\mathbf{A}_{n,\alpha}(\mathbf{k}) = i \langle\langle \psi_{n,\alpha}(\mathbf{k}), \nabla \psi_{n,\alpha}(\mathbf{k}) \rangle\rangle$
- Berry curvature $\Omega_{n,\alpha}(\mathbf{k}) = [\nabla_{\mathbf{k}} \times \mathbf{A}_{n,\alpha}(\mathbf{k})]_z$
- Z2 index

$$D_n = \frac{1}{2\pi} \sum_{\alpha=I,II} \left(\oint_{\partial\text{EBZ}} d\mathbf{k} \cdot \mathbf{A}_{n,\alpha}(\mathbf{k}) - \int_{\text{EBZ}} d^2k \Omega_{n,\alpha}(\mathbf{k}) \right) \text{ mod } 2$$

Essentially the same as Fu-Kane except for the inner product.

■ Numerical computation

- Lattice Brillouin zone calculation
Fukui, Hatsugai & Suzuki, *JPSJ* **74** (2005).
Fukui & Hatsugai, *JPSJ* **76** (2007).
- Quantized even for finite mesh

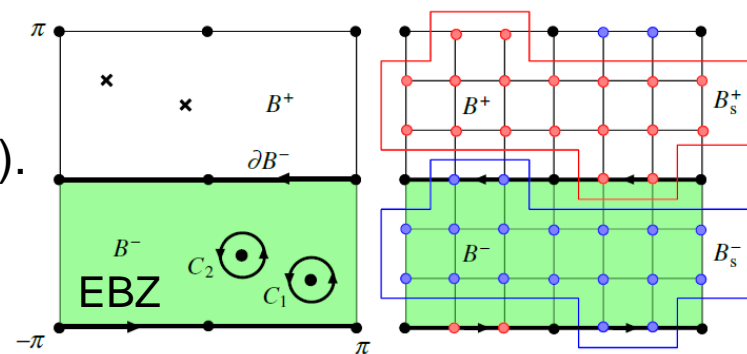

Examples

■ Kagome bilayer

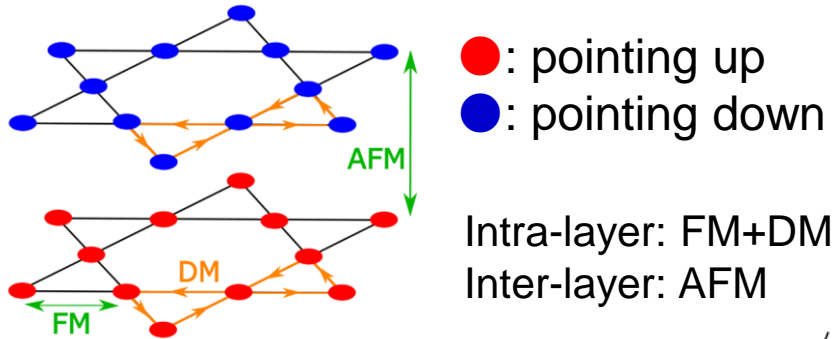

• Pseudo TR op.: $\Theta' = (\overbrace{\sigma_z}^{\text{p-h}} \otimes \overbrace{i\sigma_y}^{\text{up/down}} \otimes 1) K$

■ Honeycomb bilayer

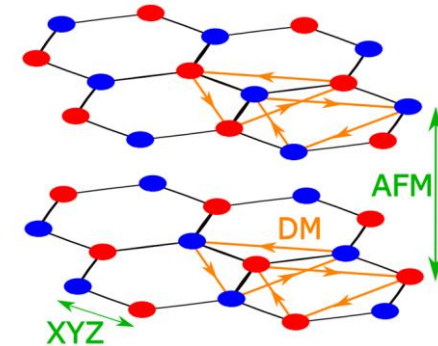

■ Magnon edge spectra

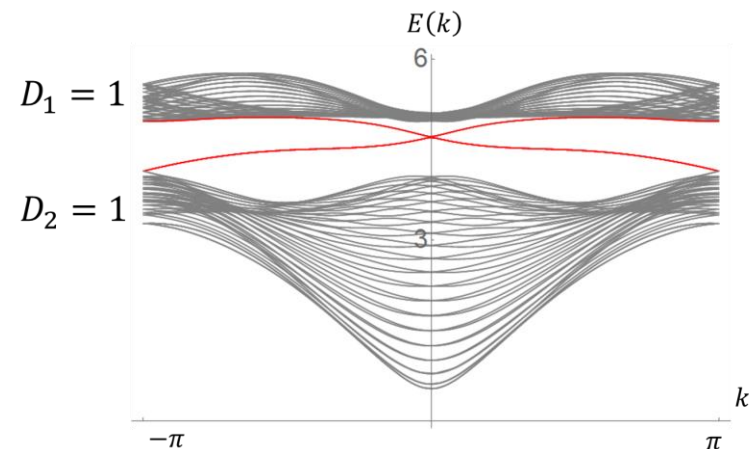
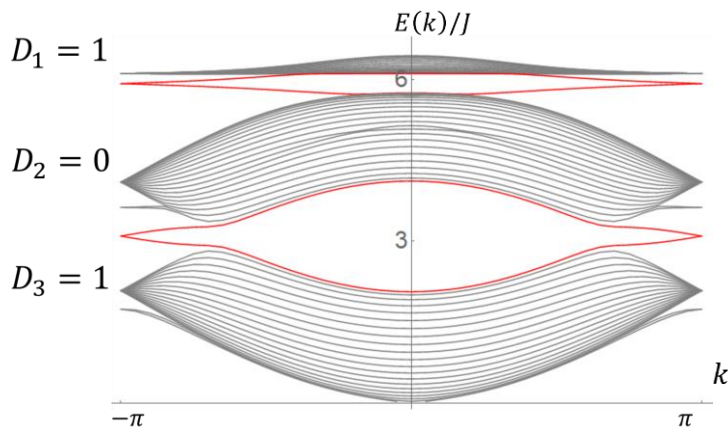

Presence/absence of the edge state \leftrightarrow Nontrivial/Trivial Z_2

Summary

- Reviewed magnon Hall effect
- Proposed magnetic analog of Z2 topo. Ins. in 2D
- Fu-Kane like formula, helical magnon edge states

Fermion (electron) in 2D	Boson (magnon) in 2D
<p>Chern insulator (A)</p> <p>Hall effect (quantized)</p> <p>Chern (TKNN) number</p>	<p>Topo. magnon insulator</p> <p>Thermal Hall effect (not quantized)</p> <p>Chern (TKNN) number</p>
<p>Quantum spin Hall ins. (All)</p> <p>Spin Hall effect</p> <p>Z2 (Kane-Mele) invariant</p>	<p>Magnon QSH insulator</p> <p>Magnon spin Nernst effect</p> <p>Z2 invariant</p>

Open questions: How to characterize weak TI, 3D bosonic TI, disorder...